

OPTION :
BOIS DUR / HARDWOOD

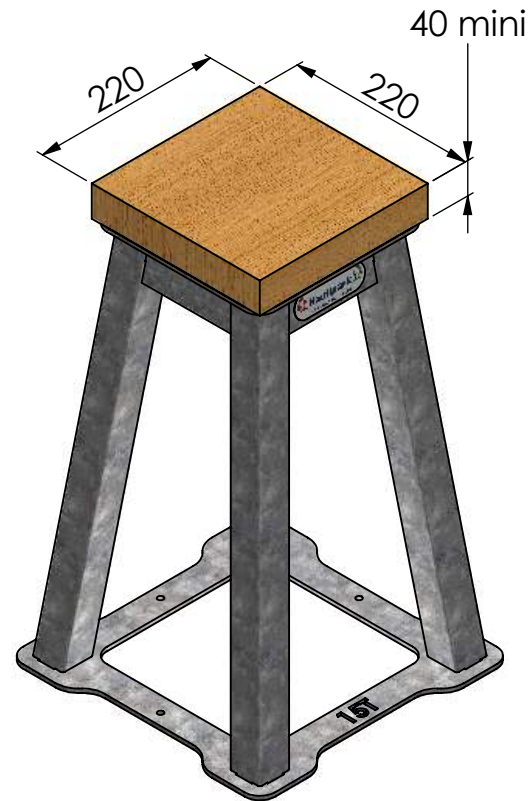

- **CMU/ SWL : 15t**
- **bois type chêne**
wood like oak
- **Epaisseur bois mini : 40mm**
Minimal wood thickness

OPTION :
INTERTECK 15t



- **CMU/ SWL : 15t**
- **INTERTECK 30-150**

OPTION :
INTERTECK 5t



- **CMU/ SWL : 5t**
- **INTERTECK 15-50**

Hauteur / height: 500mm

Masse / mass: 9.8kg

Matériau : acier galvanisé / material: galvanized steel

DONNEES TECHNIQUES / TECHNICAL DATAS

PARKTAB 15-50

PT15-50v1

JL - 05/11/2021

A3

1:7